



Wooden Planter

Safety Instructions

Notice: Ensure you read and fully understand instructions before use

While every attempt is made to ensure the highest degree of protection in all equipment, we cannot guarantee freedom from injury. The user assumes all risk of injury due to use. All merchandise is sold on this condition, which no representative of the company can waive or change.

- Make sure all fastenings are tightly in place and that everything is in order before using the product. This should be checked periodically by an adult.
- This product is not a toy, and is only to be used for its designated purpose.
- Move to the final position before filling the planter.
- Only use this product on stable, level and dry ground.
- Do not discard any of the packaging until you have checked that you have all of the parts and fittings required.
- This product is intended for outdoor use only.
- Leaving the product outside exposed to weather, especially direct sun and rain, will speed the weathering process. This can be slowed by removing the product from these conditions.
- This product contains small parts that could be a choking hazard if swallowed. Keep these items away from children.
- Use the correct fixings as indicated. Do not tighten any of the nuts until the unit is completely assembled, then finish by tightening all nuts. All nuts must be tightened before use.
- If the product is damaged or has any defects, please contact cservice@oypla.com

Operating Instructions

1. Offer the side panels of the planter to the front and rear panels (as shown) and align the upper edges.
2. Insert the screws into the predrilled holes and secure.
3. Place the base into the bottom of the planter.

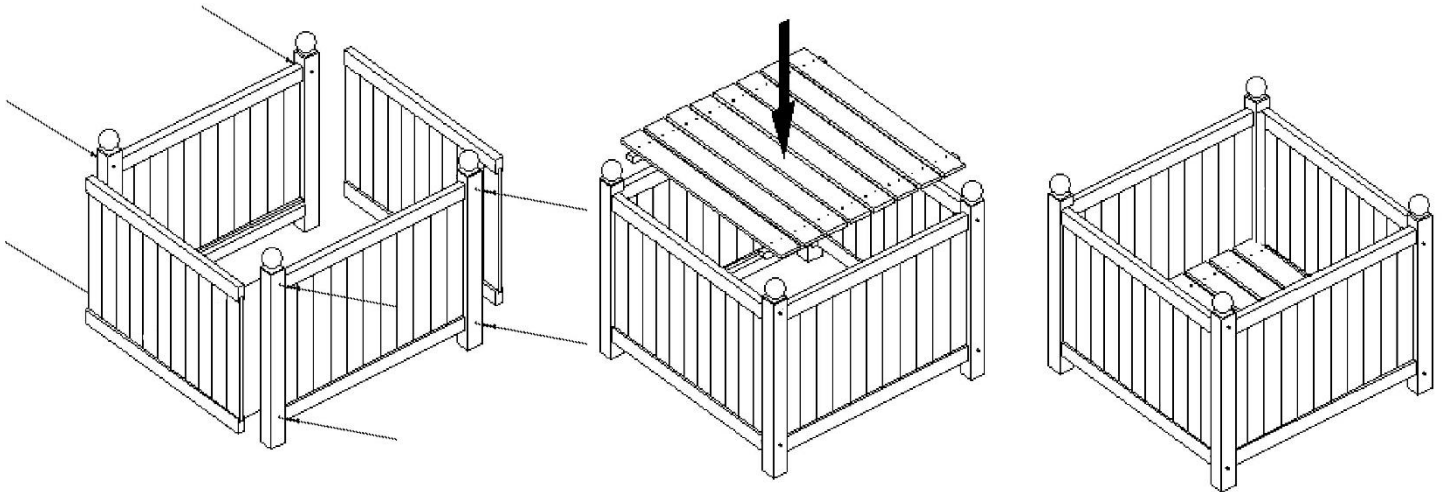

Care and Maintenance

- Line the inside of the planter with polythene sheeting before filling. Ensure that a few holes are made in the sheeting for drainage.
- Preserve the wood using timber treatment. Follow the directions on the can after first checking that it is not harmful to plants.

PLEASE RETAIN A COPY OF THESE INSTRUCTIONS FOR FUTURE CONSULTATION

HAVE A QUESTION ABOUT YOUR PURCHASE?

OUR DEDICATED CUSTOMER SERVICES TEAM ARE HAPPY TO HELP
CONTACT THEM VIA:

OYPLA.COM

An Official OYPLA Branded Product

TELEPHONE: 020 3600 2255

EMAIL: cservice@oypla.com

LIVE CHAT: www.oypla.com

Imported by Oypla.com LLP, Uxbridge, UB8 2FX

USER MANUAL Model No: 4338/4339