

# OYPLa<sup>TM</sup> DIY



## Workbench

# Safety Instructions

**Notice: Ensure you read and fully understand instructions before use**

**While every attempt is made to ensure the highest degree of protection in all equipment, we cannot guarantee freedom from injury. The user assumes all risk of injury due to use. All merchandise is sold on this condition, which no representative of the company can waive or change.**













- This product should only be used for its designated purpose. Not suitable for use by children or unauthorised persons. Do not use as a ladder.
- Do not carry out alterations or modifications to this product.
- This product contains small parts that could be a choking hazard if swallowed. Keep these items away from children.
- Do not discard any of the packaging until you have checked that you have all the parts and fittings required.
- Make sure all fastenings are tightly in place and that everything is in order before using the product. This should be checked periodically by an adult.
- Never exceed the maximum load capacity of 100kg, or it may result in product failure and/or personal injury.
- Leaving the product outside exposed to weather, especially direct sun, rain and salt air, will speed with the weathering process. This can be slowed by removing the product from these conditions, or covering it with a suitable cover.
- Only use on a stable, level and dry ground.
- Keep fingers, hair and loose clothing free from clamper at all times.
- Use the correct fixings as indicated. Do not tighten any of the nuts until the unit is completely assembled, then finish by tightening all nuts. All nuts must be tightened before use.
- Keep away from fire.
- Clean only with a damp cloth. Do not use strong industrial cleaning substances.
- If the product is damaged or has any defects, please contact [cservice@oypla.com](mailto:cservice@oypla.com)

# Operating Instructions

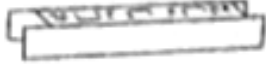
## Parts List:

If you are missing any of the below parts please contact [cservice@oypla.com](mailto:cservice@oypla.com)

Please be aware that you will be referring to this parts list throughout the assembly process.

No.	Figure	Description	Quantity (pcs)
1		Table Top	2
2		Wood Screw 4.8mm x 16mm	16
3		Slide Base	2
4		Bolts M6 x P4.0 x 28mm	8
5		Washers Ø13 x Ø6 x 0.8	20
6		Nuts (hex) M6 x P1.0	8
7		Cross Bar	2
8		Leg Frame	2
9		Plastic Pad	4
10		Bolts (hex)	6
11		Nuts (nylon) M6 X P1.2	6
12		Clamper	4

# Assembly Instructions

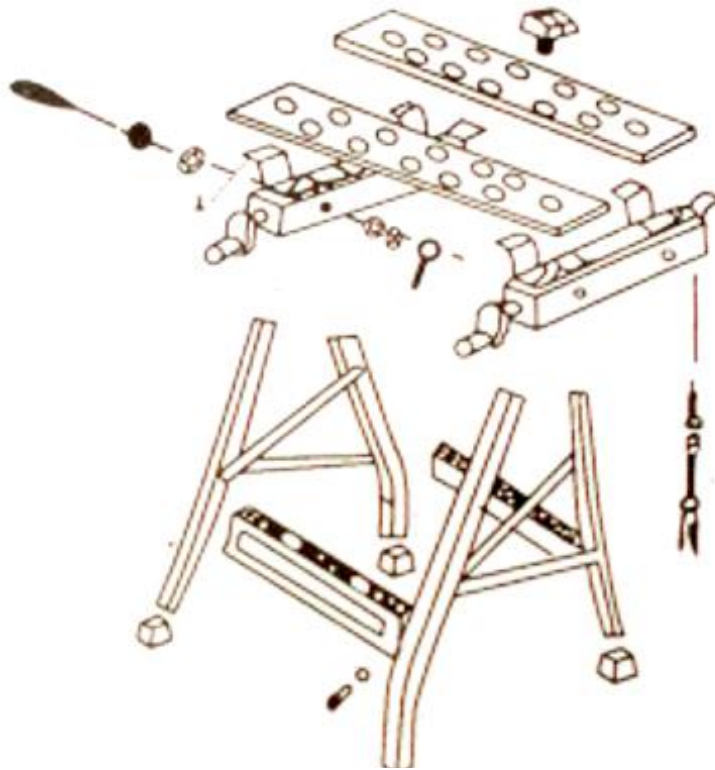

**Step 1:** Turn both parts of table top (1) upside down and use the woodscrews (2) to connect the slide base (3) with table top.

**Step 2:** Use bolts (4), washers (5) and nuts (6) to connect the cross bars (7) with the legs (8).

**Step 3:** Attach the plastic pads (9) to the legs (8).

**Step 4:** Fit the leg into slide base and line up holes of both. Then insert bolts (10) and washers (11) from the outside and attach the washers (11) and nuts (12) from the inside. Tighten bolts and nuts with spanners and screwdrivers.

**Step 5:** Select suitable holes on table top to fix the clampers (13).



**An Official Oypla Branded Product**