

OYPLA™

DIY

THANK YOU FOR YOUR ORDER



2-in-1 Pipe Bender

Safety Instructions

Notice: Ensure you read and fully understand instructions before use

While every attempt is made to ensure the highest degree of protection in all equipment, we cannot guarantee freedom from injury. The user assumes all risk of injury due to use. All merchandise is sold on this condition, which no representative of the company can waive or change.

- This product is not a toy, and is only to be used for its designated purpose.
- Never carry out any alterations or modifications to this product.
- This product is intended for use on pipes only.
- Whilst using the product, be sure to wear the correct PPE (safety goggles and good quality work gloves) to avoid causing any personal injuries.
- Keep fingers, loose clothing, and hair away from the moving parts found in the product.
- Make sure you are on stable, level and dry ground with a good footing before using the product.
- Leaving the product outside exposed to weather, especially direct sun, rain and salt air, will speed the weathering process. This can be slowed by removing the product from these conditions, or covering it with a suitable cover.
- This product is not intended for use by persons (including children) with reduced physical, sensory and mental capacities, or lack of experience and knowledge, unless they have been given supervision or instruction concerning use of the product by persons responsible for their safety.
- Clean only with a damp cloth. Do not use strong industrial cleaning substances or abrasive materials as these will damage the product.
- If the product is damaged or has any defects, please contact cservice@oypla.com

Operating Instructions

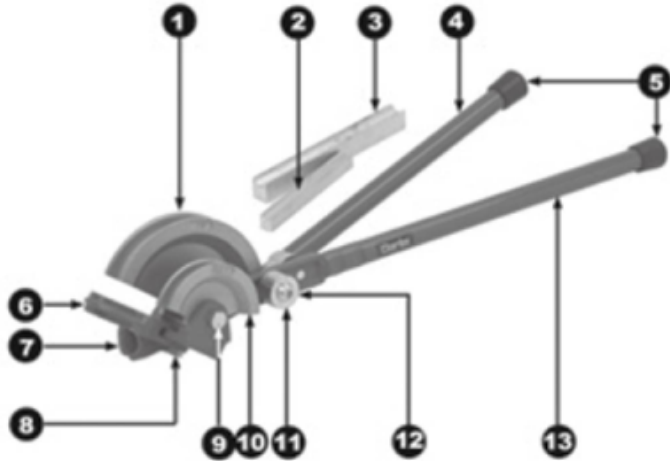

Item	Description	QTY
1	22mm Former	1
2	15mm Guide	1
3	22mm Guide	1
4	Handle	1
5	End Cap	2
6	Pipe Guide	1
7	Body	1
8	Bolt	1
9	Bolt	1
9a	Nut (not shown)	1
10	15mm Former	1
11	Roller	2
12	Screw	2
13	Handle	1

Before starting work, check that the tool is in good condition and that the rollers move freely (see Fig. 1).

Plan the bends first to ensure that all the bends you wish to make are possible. Sometimes it may be necessary to make bends and trim to length afterwards. If possible, practice on scrap pieces first to avoid creating waste.

To make a bend, open the bender fully, place the pipe into the respective former groove (15 or 22mm). Make sure the pipe passes under the piper locator. The aluminium guide is then positioned (concave face down) on top of the pipe. Ensure the guide is pushed up against the locator.

Bring the handles together until the respective roller comes into contact with the guide (continue to apply pressure to the handles until the required bend is achieved). To achieve a 180° bend, continue moving the handles together until the two ends of the pipe are parallel.

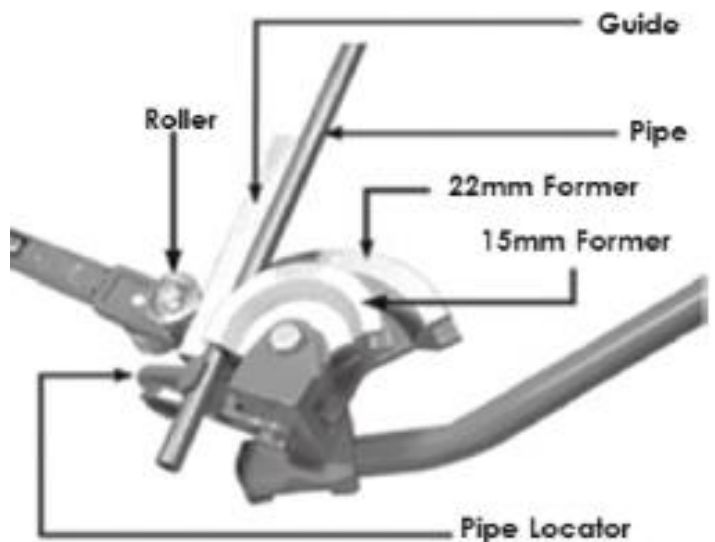

Fig.1

HAVE A QUESTION ABOUT YOUR PURCHASE?

Our dedicated customer services team are happy to help. Contact them via:

Telephone: 020 3600 22 55
Email: cservice@oypla.com
Live Chat: WWW.OYPLA.COM

CONSIDER THE ENVIRONMENT!

In the United Kingdom, approximately 5 billion corrugated boxes are used per year, amounting to around 83 per person! By recycling the cardboard box in which this product was packed, you contribute to the preservation and sustainability of the environment.

If you see a recycling logo on the packaging of your product, such as the below examples, that piece of packaging is recyclable. If there is not a recycling logo, please check with your local authorities before recycling.



PLEASE RETAIN A COPY OF THESE INSTRUCTIONS FOR FUTURE CONSULTATION

OYPLA.COM

AN OFFICIAL OYPLA BRANDED PRODUCT

Imported by Oypla.com LLP, Uxbridge, UB8 2FX

USER MANUAL Model No: 3390